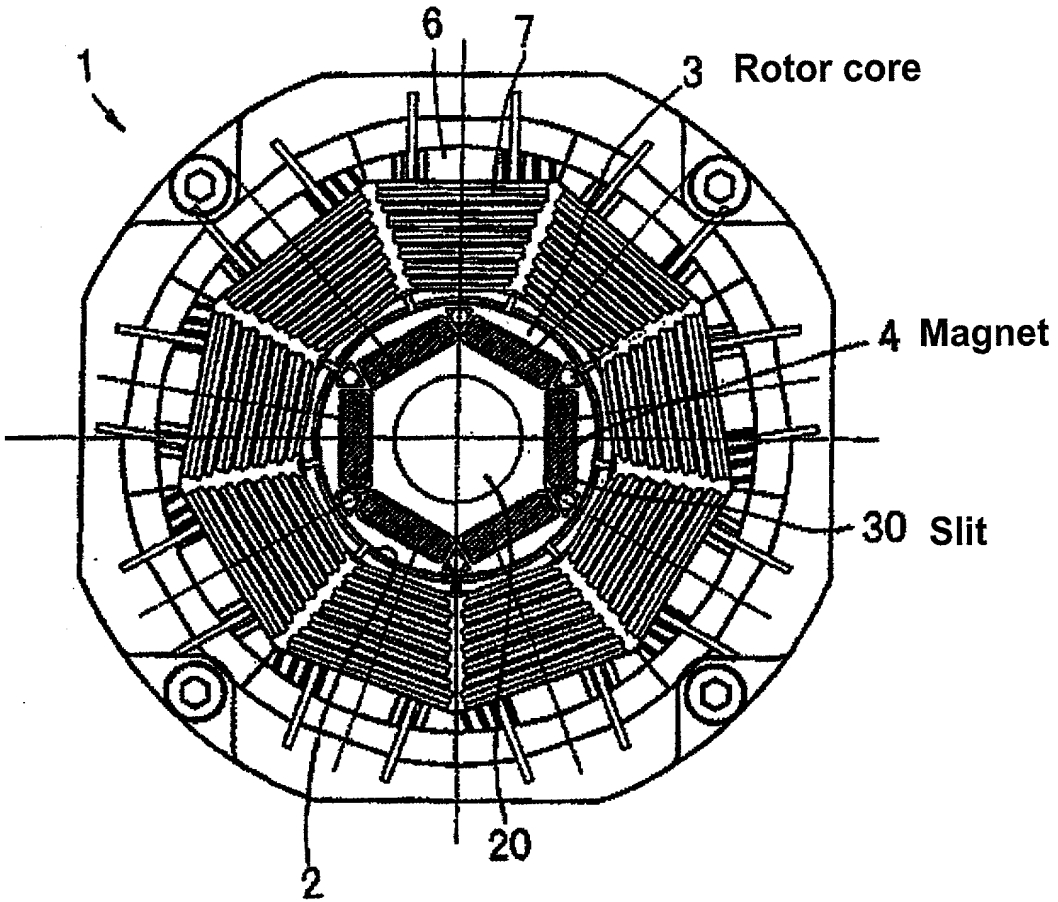
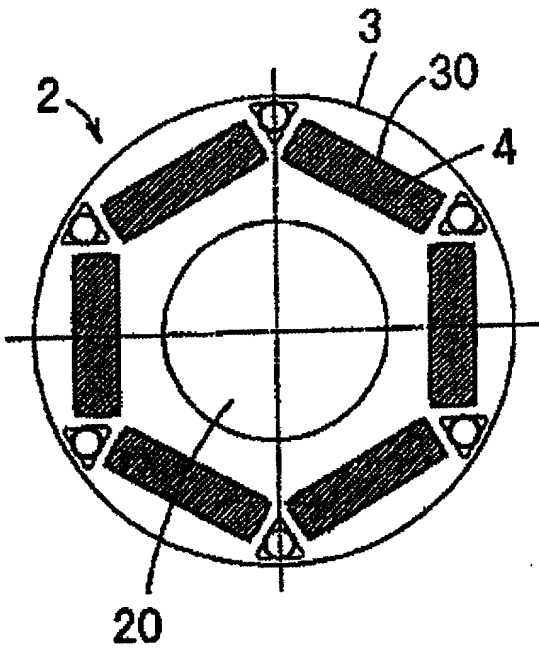

Fig. 1



FOR PUBLICATION

Fig. 2



TOP SECRET

Fig. 3

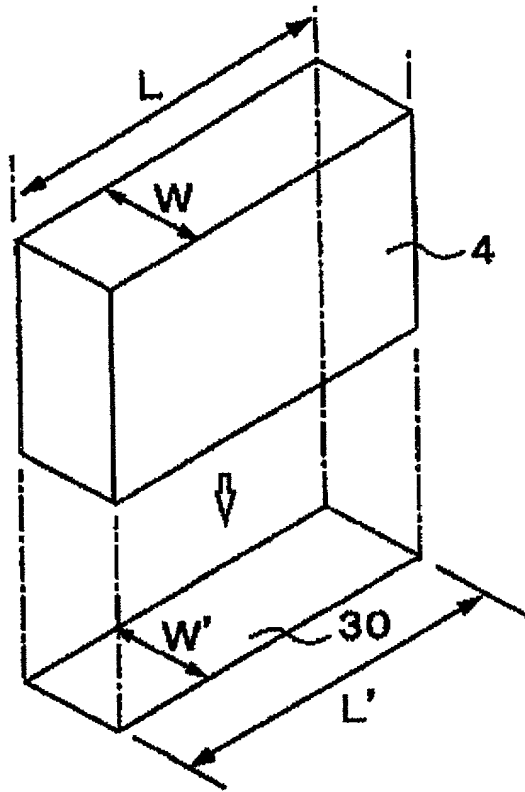

TOP SECRET

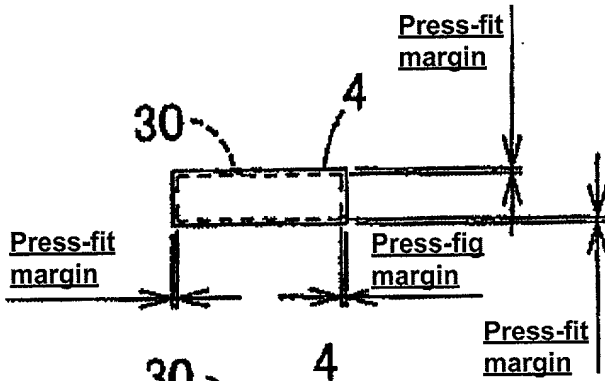

Fig. 4 (A)

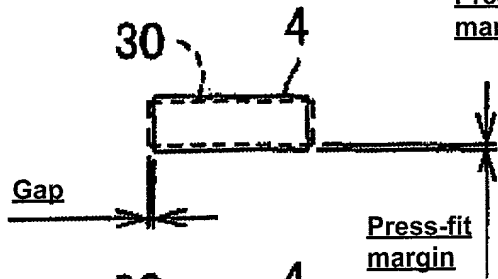

Fig. 4 (B)

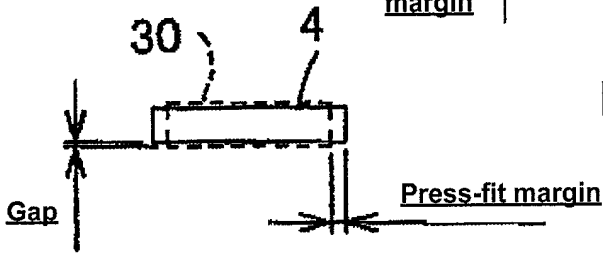
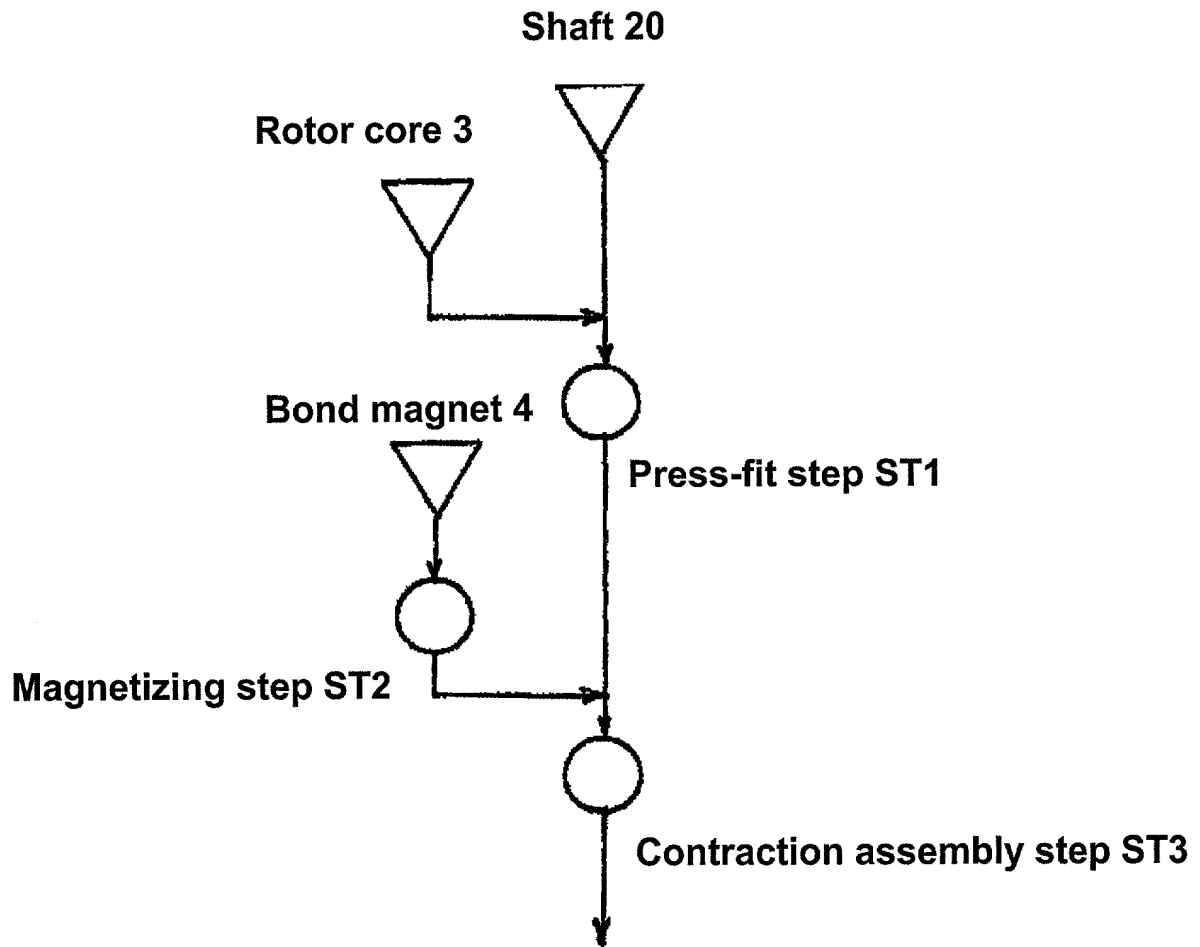

Fig. 4 (C)

Broken line: Cross section of slit
 Solid line: Cross section of magnet

Fig. 5



400360941004

Fig. 6

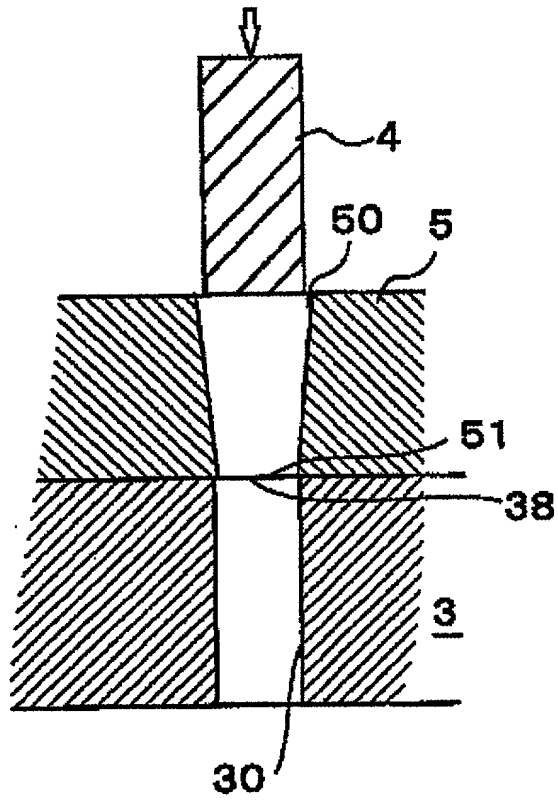

FOOTPRINT 100369801

Fig. 7

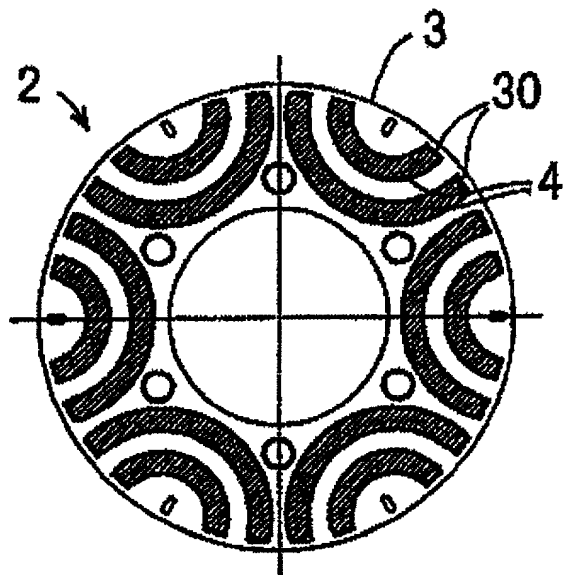
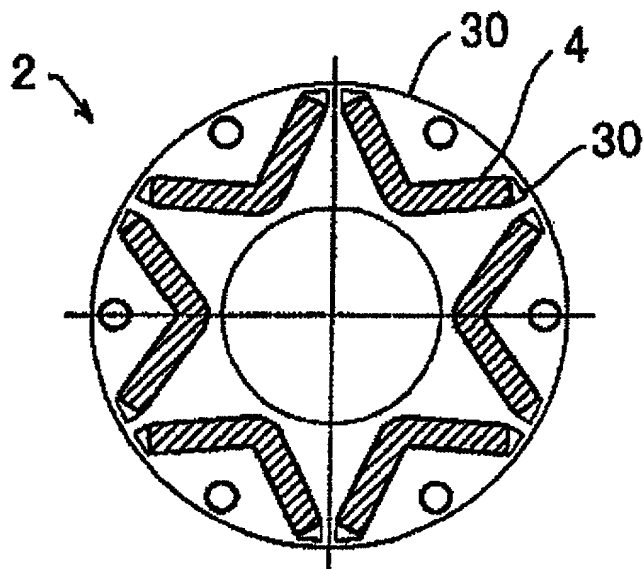

Fig. 8



TOP OF SHEET

Fig. 9

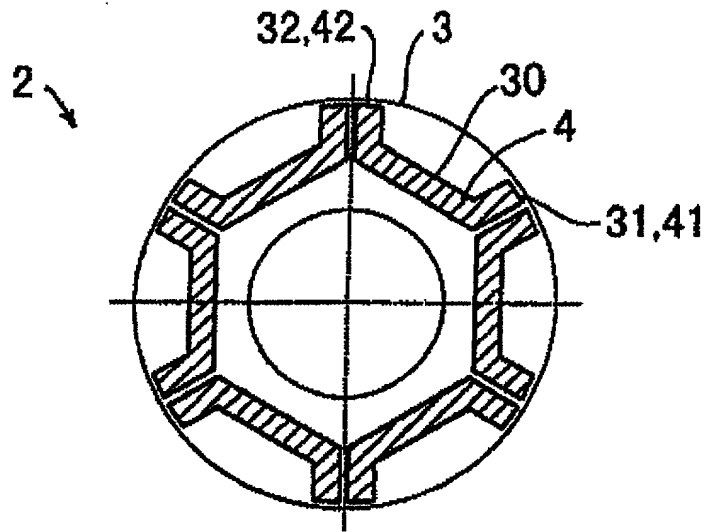

Fig. 10

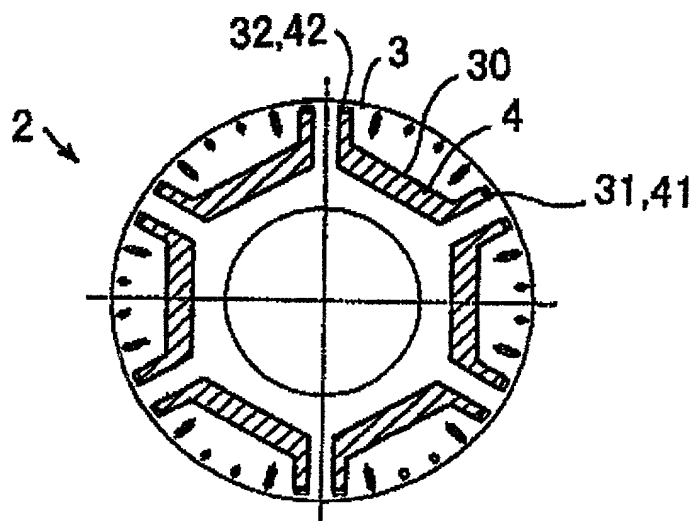

Fig. 11

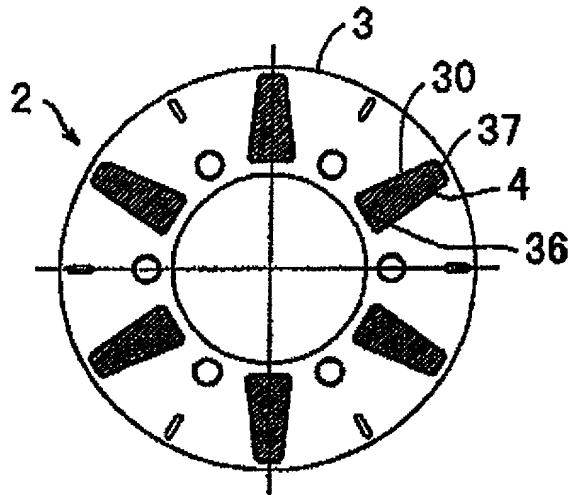

Fig. 12

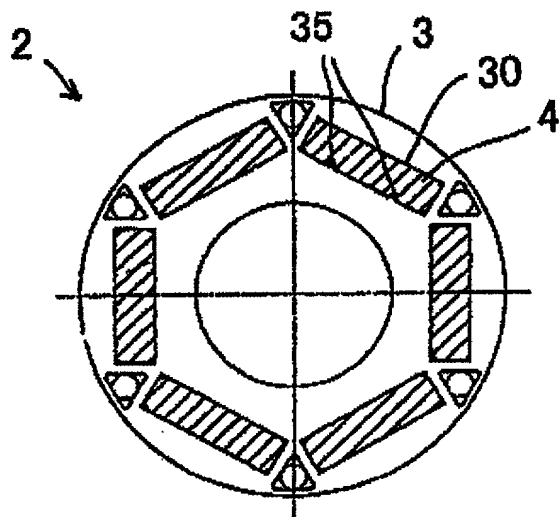

FIG. 11

Fig. 13 (A)

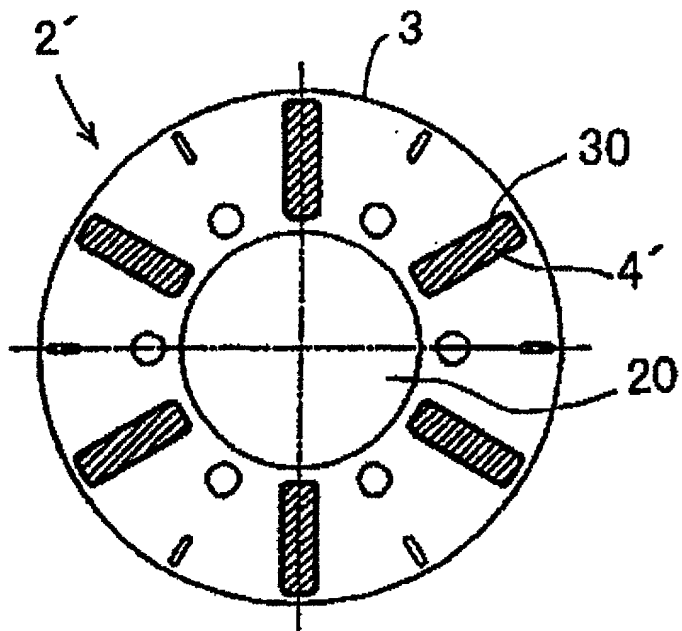

Fig. 13 (B)

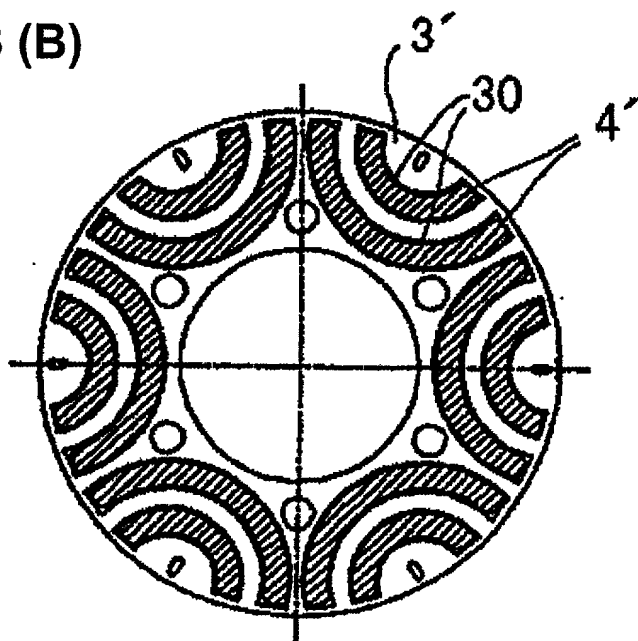
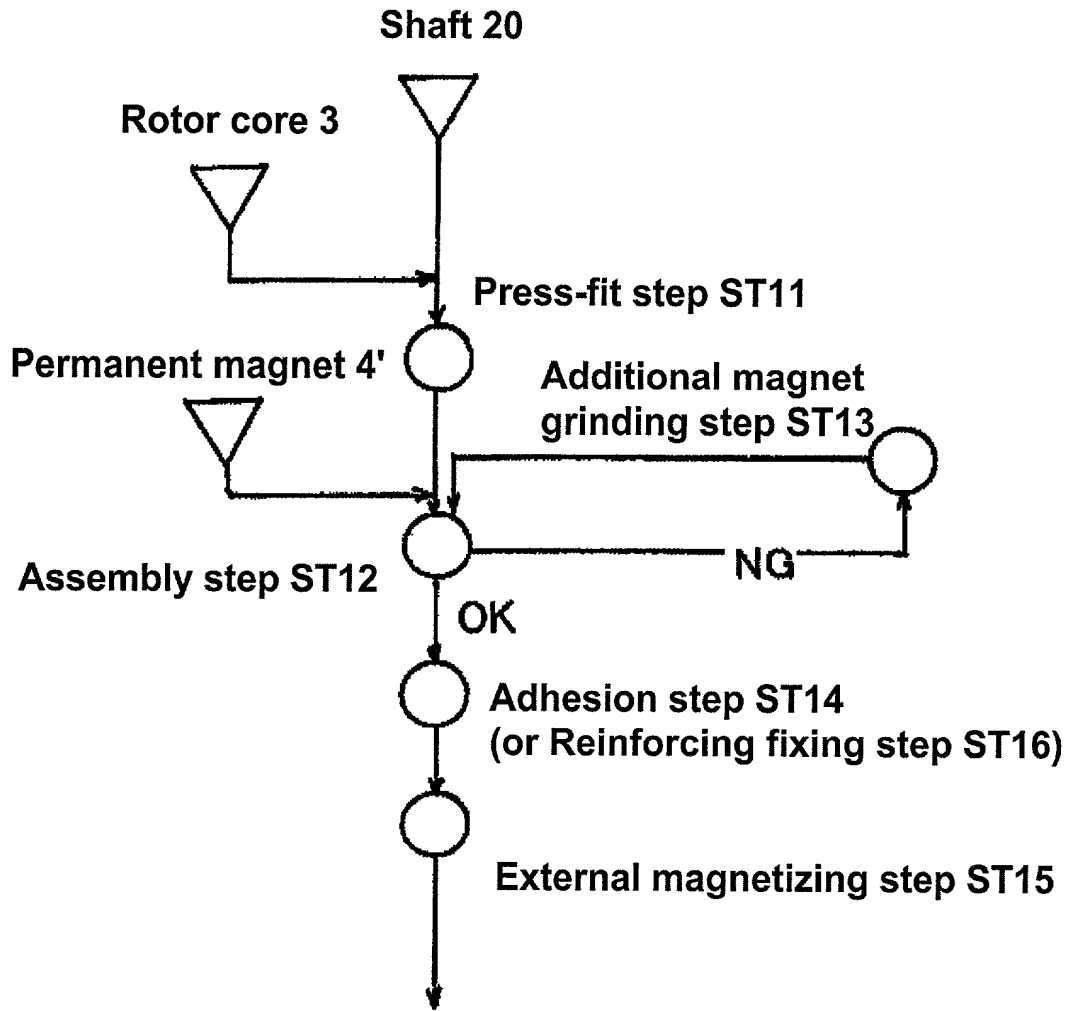

Fig. 14



FOR "060300T"